

WYLER AG, Im Hölderli 13 CH-8405 Winterthur	Datasheet ZEROTRONIC C 60°	949-DB-0044
		Revision: 1.0
		Page 1 of 4

# ZEROTRONIC C 60°

P/N: 065-040-C-60



Dimension:

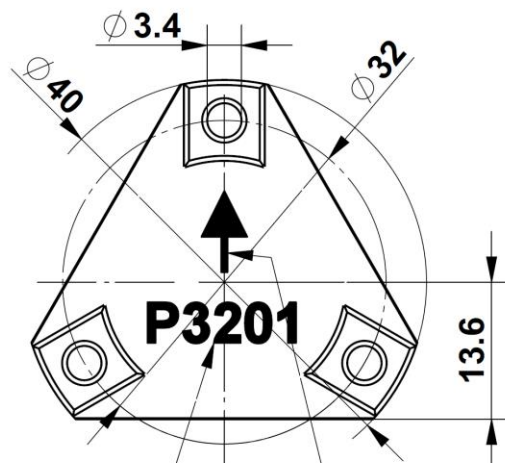
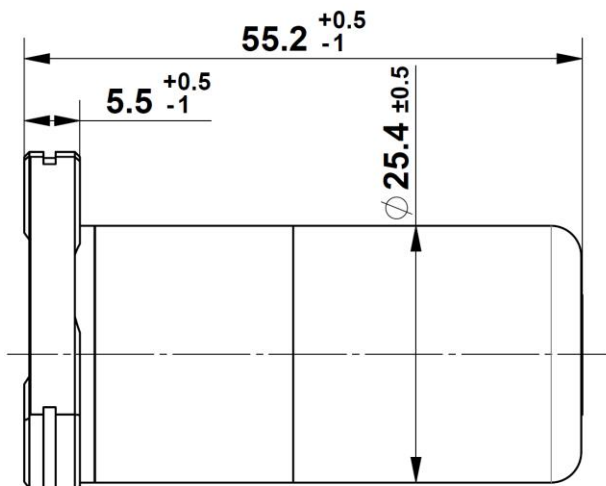

Serial number

Sensor alignment

Technical specifications	
Power consumption	ca. 100mW
Power supply	5 V ±10%
Operating and storage temperature	-40 ... 85°C
Net weight	100 g
Shock resistance	40g (11ms) / 2000g (1ms) / IEC 60068-2-27
Protection class	IP67 (only with protective cap or plugged in)

WYLER AG, Im Hölderli 13 CH-8405 Winterthur	<b>Datasheet ZEROTRONIC C 60°</b>	<b>949-DB-0044</b> <b>Revision: 1.0</b> Page 2 of 4
--	-----------------------------------	---

Technical specifications		
<b>Measuring range</b>	$\pm 60^\circ$	
<b>Limits of error</b> ( $T_A = 20^\circ\text{C}$ )	<b>24 hours</b>	<b>6 months *</b>
ZERO-POINT (Drift)	0.005% $M_E = 10.8$ arcsec	0.035% $M_E = 75.6$ arcsec
GAIN		0.027% $M_W$
Base value		+ 12 arcsec
<b>Temperature error</b> / °C ( $\varnothing 10^\circ\text{C}$ ) ( $-40^\circ\text{C} \leq T_A \leq 85^\circ\text{C}$ )		
ZERO-POINT (Drift)	0.005% $M_E = 8.64$ arcsec	
GAIN	0.030% $M_W$	
Base value if ( $T_A < 10^\circ\text{C}$ or $T_A > 30^\circ\text{C}$ )	+ 14 arcsec	
<b>Resolution</b> ( $T_A = 20^\circ\text{C}$ ) <sup>(1)</sup>	<b>/ arcsec</b>	
<b>Sampling time 0.1 sec</b>		
Single value read	54.0	
Moving average over 10 values	10.8	
<b>Sampling time 1 sec</b>		
Single value read	8.6	
Moving average over 10 values	4.3	
<b>Sampling time 8 sec</b>		
Single value read	6.5	
Moving average over 10 values	4.3	

**Remark:**

(1) Repetition is included in resolution

**Abbreviations:**
 $M_E$  = full-scale (mainly drift related)

 $M_W$  = measured value (mainly gain related)

 $T_A$  = ambient temperature

\* typical value

RS485	
<b>Value update rate</b>	max. 10 values per second
<b>Temperature reading</b>	supported
<b>Interfaces</b>	MultiTC MiniTC BlueTC BlueMETER SIGMA
<b>Connectivity</b>	wylerEXPLORER v2.0.5.0 or higher wylerSPEC v2.0.5.0 or higher wylerINSERT v2.0.4.0 or higher wylerDYNAM v2.0.0.0 or higher wylerCHART v2.0.0.0 or higher
<b>Digital output</b>	RS485, asynchronous, 7 DataBits, 2 StopBits, no parity, 57600 bps

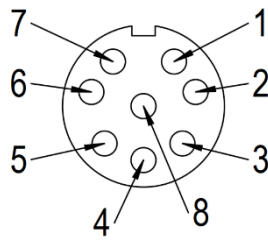
**Pinout Port**

female

Pin	Name	Description
1	--	Reserved (unconnected)
2	GND	Ground
3	+ 5V DC	+5 V DC power
4	RTA	WYLER RS485 channel A
5	RTB	WYLER RS485 channel B
6	--	Reserved (do not connect)
7	--	Reserved (do not connect)
8	--	Reserved (unconnected)

**Please Note**

To lock the connector to the ZEROTRONIC, the threaded ring is tightened until it is 'finger-tight' (approx. 0.5 Nm).

**Scope of delivery**

- 3 screws M3x10 (maximum tightening torque 0.8 Nm)
- 3 tension washers (observe installation direction)

WYLER AG, Im Holderli 13 CH-8405 Winterthur	<b>Datasheet ZEROTRONIC C 60°</b>	<b>949-DB-0044</b>
		<b>Revision: 1.0</b>
		Page 4 of 4

## Definitions

### ZERO-POINT

The table contains values for the permitted deviation of the zero-point within 24 hours and 6 months. This value is critical if the sensor is fix-mounted and the possible change of the ZERO-POINT over a period must be estimated.

**Important:** The ZERO-POINT deviation can be eliminated at any time by a reversal measurement.

### GAIN

This error contribution arises from the change over time of the GAIN. It depends on the value of the reading and has a base value at the same time.

### TEMPERATURE

The table shows the temperature coefficient per degree Celsius of temperature difference to 20°C. That means that the proportion of the error caused by the temperature at -10°C is in the same range as at +50°C.

**Important:** The temperature error can be reduced substantially by the so-called HTR calibration, in which reference values at low and high temperatures are also stored in the sensor. We recommend the HTR calibration in all applications where the ZEROTRONIC sensor is exposed to high temperature variations.

### SAMPLING TIME <> Resolution / sampling time

The word resolution describes the smallest angular value which, provided that inclination does not change, remains unchanged.

Obviously, the specified values show, long integration periods = high resolution, short integration periods = low resolution.

It is readily identifiable, that the total integration time is responsible for the resolution. Provided that all values available from the sensor are included in the integration, it is irrelevant whether the integration is done by the sensor or by external software.

At start-up of ZEROTRONIC Sensors they produce every 100 msec a new value. This sampling time may be changed by software. To each value a sequence number is attached. This allows the assurance that all produced values are available.

The **limits of error** of a sensor ZEROTRONIC must logically be calculated individually for each application by adding all relevant error contributions. If the application requires measurements at different temperatures and for a long time, these error contributions have to be analyzed in detail to determine whether the required accuracy can be achieved, or whether, for example, mechanical protective measures such as protection from direct sunlight are necessary or whether the temperature influence can be reduced with an insulated housing. Also, the application software and the integration time must be given the necessary attention.